



## 2 | BOILING FLASKS AND GENERAL LABORATORY GLASSWARE

DURAN® laboratory glassware, including heating vessels, has very good thermal-shock resistance ( $\Delta T=100$  K) and a high operating temperature (+500 °C). Not only the glass type but also its uniform wall thickness distribution are critical in preventing uneven expansion and stressing of the glass which could result in failure. For this reason, wall thickness distribution is, as a vital quality characteristic, continuously checked during the production process.

The beakers are primarily used as heating vessels. The tall shape is particularly suited to heating in liquid baths where the beaker contents are protected against the surrounding medium.

Erlenmeyer flasks are well suitable for mixing, because of their conical shape.

Weighing bottles are used when accurately weighing out substances. Close fitting lids with moulded grips are used to prevent the substances from being lost, e.g. during transport within the laboratory.

Watch glass dishes can be used both for covering beakers and Erlenmeyer flasks as well as for weighing small quantities of substances.

Our product range also includes a wide range of test tubes. In addition to DURAN® glass, other glass types are available (FIOLAX®, soda-lime). The characteristics of each glass type may be found on pages 217-221, 234.

### Usage tips:

- Due to the uniform wall thickness distribution suitable for very high temperature changes.
- The printed scale on many items of DURAN® laboratory glassware is indicative with an accuracy of  $\pm 10$  %. Therefore the items are not suitable for use as volumetric glassware.
- The products are not designed for use under differential pressure or vacuum conditions.

DURAN® beakers and Erlenmeyer flasks are provided with a retrace code. Using the eight-character code and the corresponding article number, a batch and quality certificate can be obtained at [www.duran-group.com](http://www.duran-group.com).

Mit leicht ablesbarer Graduierung und großem Schriftfeld zur einfachen Kennzeichnung. Eingebanntes und daher sehr lange haltbares Druckbild. Ausguss für sauberes Arbeiten. Aufgrund der Wandstärkenverteilung ideal zur Verwendung als Kochglas.

*With easy-to-read scale and large labeling field for easy marking in fired-on, highly durable, white ceramic. Spout for clean pouring. Uniform wall thickness distribution makes these beakers ideal for heating applications.*

DURAN® BECHER  
niedrige Form, mit Ausguss

DURAN® BEAKER  
low form, with spout

Best.-Nr. Cat. No.	Inhalt Capacity ml	d mm	h mm	Verpackungseinheit/ Stück Pack/Quantity
21 106 07 <sup>1</sup>	5 <sup>3</sup>	22	30	10
21 106 08 <sup>1</sup>	10 <sup>3</sup>	26	35	10
21 106 14	25 <sup>3</sup>	34	50	10
21 106 17	50	42	60	10
21 106 24	100	50	70	10
21 106 29	150	60	80	10
21 106 36	250	70	95	10
21 106 41	400	80	110	10
21 106 48	600	90	125	10
21 106 53	800	100	135	10
21 106 54	1 000	105	145	10
21 106 63	2 000	132	185	10
21 106 68	3 000	152	210	4
21 106 73	5 000	170	270	1
21 106 86 <sup>1,2</sup>	10 000	217	350	1

<sup>1</sup> Ohne Teilung.

<sup>2</sup> Nicht nach DIN und ISO.

<sup>3</sup> Ohne Retrace Code.

<sup>1</sup> Without graduation.

<sup>2</sup> Non-DIN/ISO size.

<sup>3</sup> Without Retrace Code.

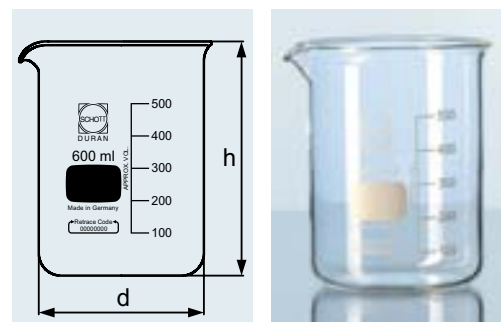

Bessere mechanische Stabilität, durch erhöhten Glaseinsatz. Verstärkter Rand erhöht Stoßfestigkeit und reduziert Bruchgefahr.

*Better mechanical stability due to increased glass content. Reinforced rim increases shock resistance and reduces risk of breakage.*

DURAN® SUPER DUTY BECHER  
niedrige Form mit Ausguss

DURAN® SUPER DUTY BEAKER  
low form with spout

Beispielhafte Anwendung: Arbeiten unter mechanischer Beanspruchung.

*Typical applications: Working under mechanical load.*

Best.-Nr. Cat. No.	Inhalt Capacity ml	d mm	h mm	Verpackungseinheit/ Stück Pack/Quantity
21 107 29 09	150	60	80	10
21 107 36 05	250	70	95	10
21 107 41 04	400	80	110	10
21 107 48 07	600	90	125	10
21 107 54 09	1 000	105	145	10
21 107 63 02	2 000	132	185	10
21 107 73 07	5 000	170	270	1

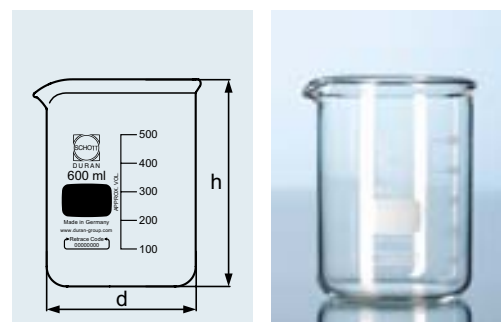

**Hinweis**

Es wird ein gleichmäßiges und langsames Erwärmen empfohlen. Bei sehr hohen Temperaturen bzw. schnellen Temperaturwechseln sollten die Standard DURAN® Becher verwendet werden.

**Note**

*Uniform and slow heating is recommended. The standard DURAN® beakers should be used when working at very high temperatures or if rapid temperature changes are expected.*

## KOCHGLÄSER UND ALLGEMEINES LABORGLAS BOILING FLASKS AND GENERAL LABORATORY GLASSWARE

### DURAN® BECHER dickwandig (Filtrierbecher)

### DURAN® BEAKER heavy-wall (filtering beaker)

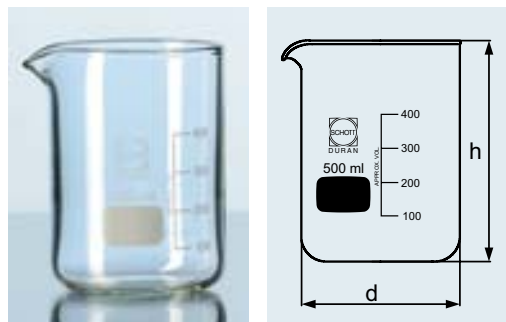

Mit leicht ablesbarer Graduierung und großem Schriftfeld zur einfachen Kennzeichnung. Eingebanntes und daher sehr lange haltbares Druckbild. Aufgrund der erhöhten Wandstärke bessere mechanische Eigenschaften als die Standard-Becher, jedoch reduzierte Temperaturwechselbeständigkeit und somit nur begrenzt als Kochglas verwendbar. Ausguss für sauberes Arbeiten.

*With easy-to-read scale and large labelling field for easy marking in fired-on, highly durable, white ceramic. Has, due to the increased wall thickness, better mechanical properties than the standard beaker. Thermal shock resistance, however, is reduced so only limited application for heating. Spout for clean pouring.*

Best.-Nr. Cat. No.	Inhalt Capacity ml	d mm	h mm	Verpackungseinheit/ Stück Pack/Quantity
21 131 24	100	52	85	10
21 131 29	150	54	93	10
21 131 36	250	70	94	10
21 131 44	500	89	124	10
21 131 54	1 000	105	160	10
21 131 63	2 000	135	195	10
21 131 68	3 000	157	205	4
21 131 73	5 000	182	256	1
21 131 86 <sup>1</sup>	10 000	225	340	1
21 131 88 <sup>1</sup>	15 000	260	390	1
21 131 91 <sup>1</sup>	20 000	285	430	1

<sup>1</sup> Ohne Teilung.

<sup>1</sup> Without graduation.

### DURAN® BECHER hohe Form, mit Ausguss

### DURAN® BEAKER high form, with spout

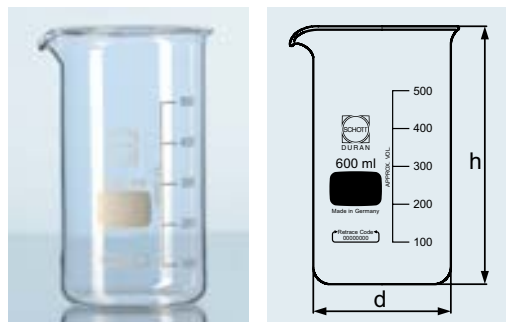

Mit leicht ablesbarer Graduierung und großem Schriftfeld zur einfachen Kennzeichnung. Eingebanntes und daher sehr lange haltbares Druckbild. Ausguss für sauberes Arbeiten. Aufgrund der Wandstärkenverteilung ideal zur Verwendung als Kochglas.

*With easy-to-read scale and large labelling field for easy marking in fired-on, highly durable, white ceramic. Spout for clean pouring. Uniform wall thickness distribution makes these beakers ideal for heating applications.*

Best.-Nr. Cat. No.	Inhalt Capacity ml	d mm	h mm	Verpackungseinheit/ Stück Pack/Quantity
21 116 17	50	38	70	10
21 116 24	100	48	80	10
21 116 29	150	54	95	10
21 116 36	250	60	120	10
21 116 41	400	70	130	10
21 116 48	600	80	150	10
21 116 53	800	90	175	10
21 116 54	1 000	95	180	10
21 116 63	2 000	120	240	10
21 116 68	3 000	135	280	2

Mit leicht ablesbarer Graduierung und großem Schriftfeld zur einfachen Kennzeichnung. Eingebanntes und daher sehr lange haltbares Druckbild. Aufgrund der Wandstärkenverteilung ideal zur Verwendung als Kochglas.

*With easy-to-read scale and large labelling field for easy marking in fired-on, highly durable, white ceramic. Uniform wall thickness distribution makes these beakers ideal for heating applications.*

**DURAN® BECHER**  
**hohe Form, ohne Ausguss**

**DURAN® BEAKER**  
**high form, without spout**

Best.-Nr. Cat. No.	Inhalt Capacity ml	d mm	h mm	Verpackungseinheit/ Stück Pack/Quantity
21 117 17	50	38	70	10
21 117 24	100	48	80	10
21 117 29	150	54	95	10
21 117 36	250	60	120	10
21 117 41	400	70	130	10
21 117 48	600	80	150	10
21 117 54	1 000	95	180	10

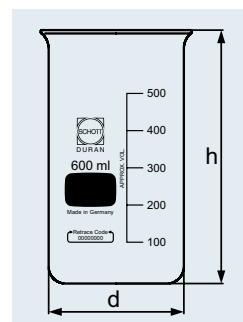

Der Ausguss ermöglicht ein sauberes Arbeiten.

*Spout for clean pouring.*

**DURAN® PHILIPSBECHER**  
**mit Ausguss**

**DURAN® PHILIPS BEAKER**  
**with spout**

Best.-Nr. Cat. No.	Inhalt Capacity ml	d mm	h mm	Verpackungseinheit/ Stück Pack/Quantity
21 141 29	150	59	87	10
21 141 36	250	68	105	10
21 141 44	500	86	142	10

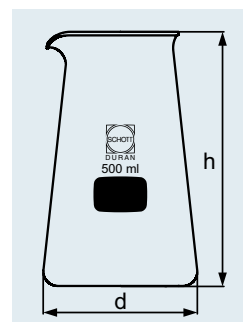

Best.-Nr. Cat. No.	Inhalt Capacity ml	d mm	h mm	Verpackungseinheit/ Stück Pack/Quantity
21 126 01	100	50	78	10

**DURAN® BERZELIUSBECHER**  
**ohne Ausguss**

**DURAN® BERZELIUS BEAKER**  
**without spout**

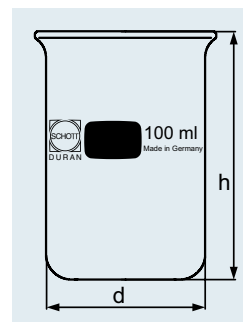

**KOCHGLÄSER UND ALLGEMEINES LABORGLAS**  
**BOILING FLASKS AND GENERAL LABORATORY GLASSWARE**

DURAN® BLOOMTESTGLAS

DURAN® BLOOM TEST VESSEL

Best.-Nr. Cat. No.	d	h	Verpackungseinheit/ Stück Pack/Quantity
	mm	mm	
21 125 01	59	85	10

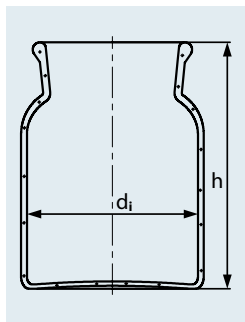

DIN  
53260

A  
121 °C



**DURAN® Produkte mit individueller Markierung**

Laserkennzeichnung, z.B. bei Seriennummern, Barcodes, Logos oder Namen

Keine Einschränkungen der Produkteigenschaften. Weitere Informationen erhalten Sie auf Seite 199

**DURAN® products with individual labelling**

Innovative laser marking, e.g.: Numbering, bar codes, logos or names

No effect on the product performance. More information, see page 229

Mit leicht ablesbarer Graduierung und großem Schriftfeld zur einfachen Kennzeichnung. Eingebanntes und daher sehr lange haltbares Druckbild. Durch die konische Form ideal zum Mischen von Flüssigkeiten. Aufgrund der Wandstärkenverteilung ideal zur Verwendung als Kochglas geeignet.

*With easy-to-read scale and large labelling field for easy marking in fired-on, highly durable, white ceramic. Due to conical form, suited to the mixing of liquids. Uniform wall thickness distribution makes these flasks ideal for heating applications.*

Best.-Nr. Cat. No.	Inhalt Capacity ml	d	d <sub>i</sub>	h	Verpackungseinheit/ Stück Pack/Quantity
21 216 14	25 <sup>2</sup>	42	22	75	10
21 216 17	50	51	22	90	10
21 216 24	100	64	22	105	10
21 216 28	125	67	28	112	10
21 990 27 <sup>1</sup>	150	74	28	118	10
21 216 32 <sup>1</sup>	200	79	34	131	10
21 216 36	250	85	34	145	10
21 216 39 <sup>1</sup>	300	87	34	156	10
21 216 44	500	105	34	180	10
21 216 54	1 000	131	42	220	10
21 216 63	2 000	166	50	280	10
21 216 68	3 000	187	52	310	2
21 216 73	5 000	220	52	365	1

<sup>1</sup> Nicht nach DIN ISO.

<sup>2</sup> Ohne Retrace Code.

<sup>1</sup> Non-DIN ISO size.

<sup>2</sup> Without Retrace Code.

Bessere mechanische Stabilität, durch erhöhten Glaseinsatz. Verstärkter Rand erhöht Stoßfestigkeit und reduziert Bruchgefahr.

*Better mechanical stability due to increased glass content. Reinforced rim increases shock resistance and reduces risk of breakage.*

Beispielhafte Anwendung: Arbeiten unter mechanischer Beanspruchung.

*Typical applications: Working under mechanical load.*

Best.-Nr. Cat. No.	Inhalt Capacity ml	d	d <sub>i</sub>	h	Verpackungseinheit/ Stück Pack/Quantity
21 217 14 08	25	42	22	75	10
21 217 17 08	50	51	22	90	10
21 217 24 04	100	64	22	105	10
21 217 26 06	250	85	34	145	10
21 217 04 40	500	105	34	180	10
21 217 54 01	1 000	131	42	220	10
21 217 63 03	2 000	166	50	280	10
21 217 73 08	5 000	220	52	365	1

#### Hinweis

Es wird ein gleichmäßiges und langsames Erwärmen empfohlen. Bei sehr hohen Temperaturen bzw. schnellen Temperaturwechseln sollten die Standard DURAN® Erlenmeyerkolben verwendet werden.

#### Note

*Uniform and slow heating is recommended. The standard DURAN® Erlenmeyer flasks should be used when working at very high temperatures or if rapid temperature changes are expected.*

### DURAN® ERLLENMEYERKOLBEN enghalsig

### DURAN® ERLLENMEYER FLASK narrow neck

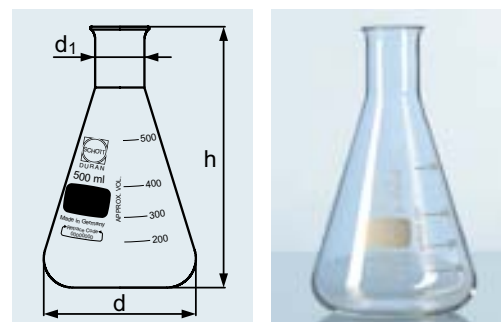

Sortimentserweiterung!  
Extended range!

### DURAN® SUPER DUTY ERLENMEYERKOLBEN enghalsig

### DURAN® SUPER DUTY ERLLENMEYER FLASK narrow neck

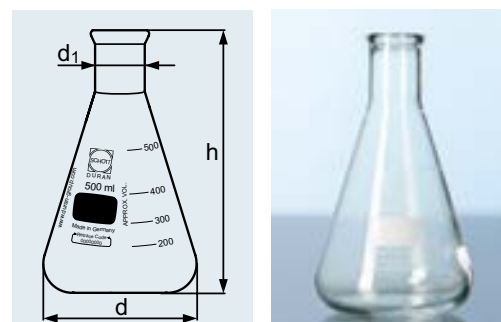

**DURAN® ERLLENMEYERKOLBEN**

weithalsig

**DURAN® ERLLENMEYER FLASK**

wide neck

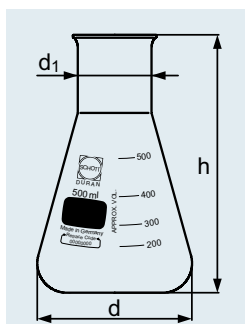

Mit leicht ablesbarer Graduierung und großem Schriftfeld zur einfachen Kennzeichnung. Eingebanntes und daher sehr lange haltbares Druckbild. Durch die konische Form ideal zum Mischen von Flüssigkeiten. Aufgrund der Wandstärkenverteilung außerdem zur Verwendung als Kochglas geeignet. Der weite Hals ermöglicht ein komfortables Befüllen und Reinigen.

*With easy-to-read scale and large labelling field for easy marking in fired-on, highly durable, white ceramic. Due to conical form, suited to the mixing of liquids. Uniform wall thickness distribution makes these flasks ideal for heating applications. The wide neck enables easy filling and cleaning.*

Best.-Nr. Cat. No.	Inhalt Capacity ml	d mm	d <sub>1</sub> mm	h mm	Verpackungseinheit/ Stück Pack/Quantity
21 226 14 <sup>1</sup>	25 <sup>2</sup>	43	31	70	10
21 226 17	50	51	34	85	10
21 226 24	100	64	34	105	10
21 226 32 <sup>1</sup>	200	79	50	131	10
21 226 36	250	85	50	140	10
21 226 39 <sup>1</sup>	300	87	50	156	10
21 226 44	500	105	50	175	10
21 226 54	1 000	131	50	220	10
21 226 63 <sup>1</sup>	2 000	153	72	276	10

<sup>1</sup> Nicht nach DIN EN ISO.

<sup>2</sup> Ohne Retrace Code.

<sup>1</sup> Non-DIN EN ISO size.

<sup>2</sup> Without Retrace Code.

**DURAN® SUPER DUTY ERLLENMEYERKOLBEN**

weithalsig

**DURAN® SUPER DUTY ERLLENMEYER FLASK**

wide neck

**NEU  
NEW**

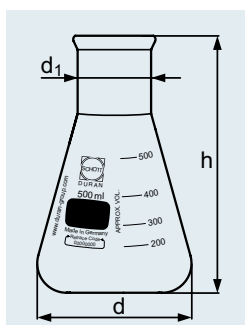

Bessere mechanische Stabilität, durch erhöhten Glaseinsatz. Verstärkter Rand erhöht Stoßfestigkeit und reduziert Bruchgefahr.

*Better mechanical stability due to increased glass content. Reinforced rim increases shock resistance and reduces risk of breakage.*

Beispielhafte Anwendung: Arbeiten unter mechanischer Beanspruchung.

*Typical applications: Working under mechanical load.*

Best.-Nr. Cat. No.	Inhalt Capacity ml	d mm	d <sub>1</sub> mm	h mm	Verpackungseinheit/ Stück Pack/Quantity
21 227 24 02	100	64	34	105	10
21 227 36 04	250	85	50	140	10
21 227 44 03	500	105	50	175	10
21 227 54 08	1 000	131	50	220	10

**Hinweis**

Es wird gleichmäßiges und langsames Erwärmen empfohlen. Bei sehr hohen Temperaturen bzw. schnellen Temperaturwechseln sollten die Standard DURAN® Erlenmeyerkolben verwendet werden.

**Note**

*Uniform and slow heating is recommended. The standard DURAN® Erlenmeyer flasks should be used when working at very high temperatures or if rapid temperature changes are expected.*



Mit leicht ablesbarer Graduierung und großem Schriftfeld zur einfachen Kennzeichnung. Eingebanntes und daher sehr lange haltbares Druckbild. Der Kolben kann mit einem PBT-Verschluss<sup>1</sup> oder Membran-Verschluss<sup>2</sup> (Gasaustausch möglich) verschlossen werden.

Beispielhafte Anwendungen: Der Kolben ist sowohl zur Lagerung, als auch zur Kultivierung geeignet.

*With easy-to-read scale and large labelling field for easy marking in fired-on, highly durable, white ceramic. The flask can be closed with a PBT cap<sup>1</sup> or membrane cap<sup>2</sup> (permits gas exchange).*

*Typical applications: The flask is suitable for storage, media preparation and cultivation.*

**DURAN® ERLIENMEYERKOLBEN**  
**mit DIN-Gewinde**

**DURAN® ERLIENMEYER FLASK**  
**with DIN thread**

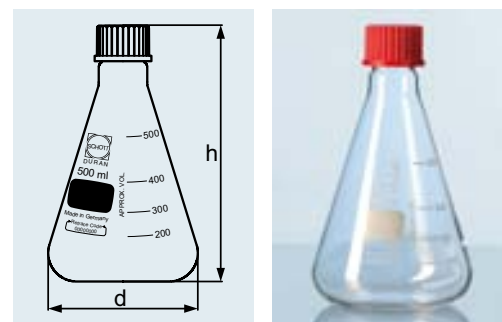

Best.-Nr. Cat. No.	Inhalt Capacity ml	DIN-Gewinde DIN thread GL	d mm	h mm	Verpackungseinheit/ Stück Pack/Quantity
21 803 24	100	25	64	105	10
21 803 24 5 <sup>3</sup>	100	25	64	109	10
21 803 36	250	32	85	145	10
21 803 36 5 <sup>3</sup>	250	32	85	149	10
21 803 44	500	32	105	175	10
21 803 44 5 <sup>3</sup>	500	32	105	180	10
21 803 54	1 000	32	131	220	10
21 803 54 5 <sup>3</sup>	1 000	32	131	225	10

<sup>1</sup> PBT-Verschluss siehe Seite 179.

<sup>2</sup> Membran-Verschluss siehe Seite 34.

<sup>3</sup> Mit PBT-Verschluss.

<sup>1</sup> PBT cap, see page 179.

<sup>2</sup> Membrane cap, see page 34.

<sup>3</sup> With PBT cap.

**DURAN® JODZAHLKOLBEN**  
**Erlenmeyerform, mit Normschliff**  
**und Glasstopfen**

*DURAN® IODINE FLASK*  
*Erlenmeyer shape, with standard ground joint*  
*and glass stopper*

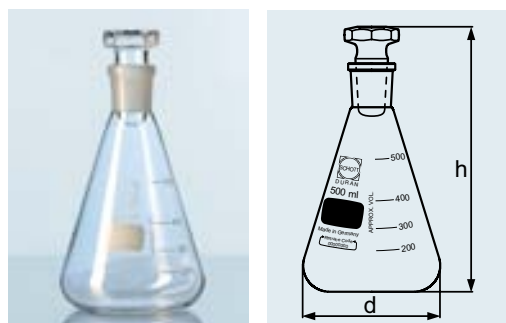

Mit leicht ablesbarer Graduierung und großem Schriftfeld zur einfachen Kennzeichnung. Eingebanntes und daher sehr lange haltbares Druckbild. Der Kolben kann mit einem Glasstopfen verschlossen werden.

*With easy-to-read scale and large labelling field for easy marking in fired-on, highly durable, white ceramic. The flask can be closed with a glass stopper.*

*Typical applications: the iodine flask is suitable for determining the iodine number, i.e. the content of unsaturated fatty acids in oils and fats.*

Beispielhafte Anwendungen: Der Jodzahlkolben dient zur Bestimmung der Jodzahl, also des Gehaltes an ungesättigten Fettsäuren in Ölen und Fetten.

Best.-Nr. Cat. No.	Inhalt Capacity ml	NS	d mm	h mm	Verpackungseinheit/ Stück Pack/Quantity
24 192 27	100	29/32	64	120	10
24 192 37	250	29/32	85	160	10
24 192 46	500	29/32	105	195	10
24 192 56	1 000	29/32	131	235	10

**DURAN® ANSETZFLASCHE**  
**Erlenmeyerform, weithalsig**

*DURAN® CONICAL FLASK*  
*Erlenmeyer shape, wide neck*

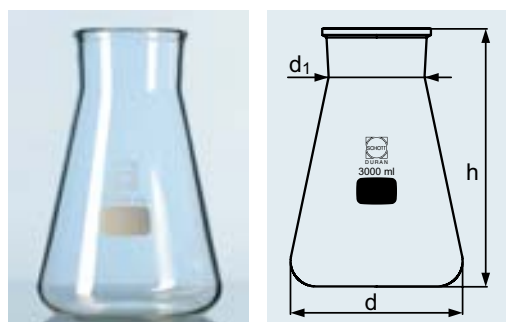

Best.-Nr. Cat. No.	Inhalt Capacity ml	d mm	d <sub>1</sub> mm	h mm	Verpackungseinheit/ Stück Pack/Quantity
21 227 68 <sup>1</sup>	3 000	190	106	285	1
21 227 73 <sup>1</sup>	5 000	220	108	322	1
21 227 86 <sup>1</sup>	10 000	285	147	420	1

<sup>1</sup> Ohne Teilung.

<sup>1</sup> Without graduation.

Rundkolben eignen sich durch die gleichmäßige Wandstärke ideal als Kochglas. Die Geometrie ermöglicht eine sehr gleichmäßige Erhitzung. Kolben mit einem Halsdurchmesser von 65 mm und mehr haben einen verstärkten Rand.

*Uniform wall thickness distribution makes these flasks ideal for heating applications. The geometry permits very uniform heating. Flasks with a neck diameter of 65 mm or more have a reinforced rim.*

DURAN® RUNDKOLBEN  
enghalsig, mit Bördelrand

DURAN® ROUND BOTTOM FLASK  
narrow neck, with beaded rim

Best.-Nr. Cat. No.	Inhalt Capacity ml	d mm	d <sub>1</sub> mm	h mm	Verpackungseinheit/ Stück Pack/Quantity
21 721 17	50	51	26	95	10
21 721 24	100	64	26	110	10
21 721 36	250	85	34	144	10
21 721 44	500	105	34	168	10
21 721 54	1 000	131	42	200	10
21 721 64 <sup>1</sup>	2 000	166	42	260	10
21 721 68 <sup>1</sup>	3 000	185	50	260	1
21 721 71	4 000	207	52	290	1
21 721 73 <sup>1</sup>	5 000	223	50	305	1
21 721 77 <sup>1</sup>	6 000	236	51	355	1
21 721 86	10 000	279	65	380	1
21 721 87 <sup>1,2</sup>	12 000	295	65	380	1
21 721 91 <sup>2</sup>	20 000	345	76	515	1

<sup>1</sup> Nicht nach DIN ISO.

<sup>2</sup> Nach ASTM E 1403.

<sup>1</sup> Non-DIN ISO size.

<sup>2</sup> Conforms to ASTM E 1403.

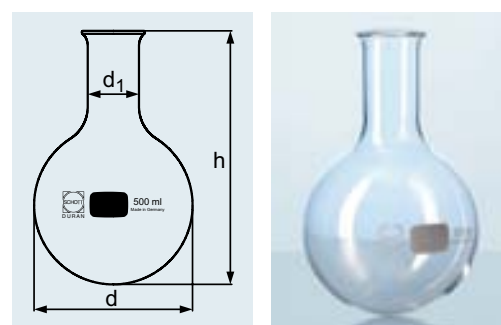

Rundkolben eignen sich durch die gleichmäßige Wandstärke ideal als Kochglas. Die Geometrie ermöglicht eine sehr gleichmäßige Erhitzung. Der weite Hals ermöglicht ein komfortables Befüllen und Entnehmen des Kolbeninhaltes. Kolben mit einem Halsdurchmesser von 76 mm und mehr haben einen verstärkten Rand.

*Uniform wall thickness distribution makes these flasks ideal for heating applications. The geometry permits very uniform heating. The wide neck permits easy filling and removal of flask contents. Flasks with a neck diameter of 76 mm or more have a reinforced rim.*

DURAN® RUNDKOLBEN  
weithalsig, mit Bördelrand

DURAN® ROUND BOTTOM FLASK  
wide neck, with beaded rim

Best.-Nr. Cat. No.	Inhalt Capacity ml	d mm	d <sub>1</sub> mm	h mm	Verpackungseinheit/ Stück Pack/Quantity
21 741 17 <sup>1</sup>	50	51	34	105	10
21 741 24	100	64	35	110	10
21 741 36	250	85	51	143	10
21 741 44	500	105	50	168	10
21 741 54	1 000	131	50	200	10
21 741 55 <sup>1</sup>	1 000	131	65	200	10
21 741 63	2 000	165	76	240	10
21 741 64 <sup>1</sup>	2 000	166	50	240	10
21 741 68 <sup>1</sup>	3 000	185	65	260	1
21 741 71	4 000	206	76	290	1
21 741 73 <sup>1</sup>	5 000	223	65	310	1
21 741 76	6 000	236	89	330	1
21 741 77 <sup>1</sup>	6 000	236	65	330	1
21 741 86 <sup>1</sup>	10 000	279	89	420	1
21 741 91 <sup>1</sup>	20 000	345	89	520	1

<sup>1</sup> Nicht nach DIN EN ISO.

<sup>1</sup> Non-DIN EN ISO size.

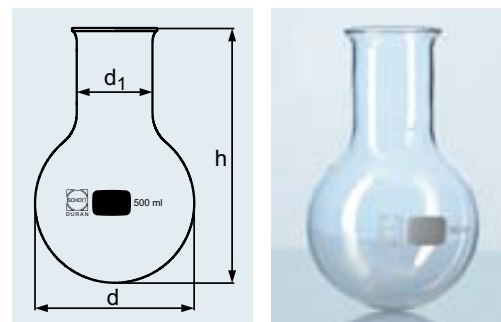

**DURAN® STEHKOLBEN**  
**enghalsig, mit Bördelrand**

**DURAN® FLAT BOTTOM FLASK**  
**narrow neck, with beaded rim**

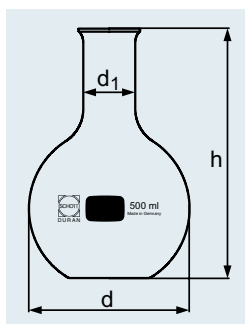

Stehkolben eignen sich durch die gleichmäßige Wandstärke ideal als Kochglas. Durch den flachen Boden kann der Kolben abgestellt werden. Kolben mit einem Halsdurchmesser von 65 mm haben einen verstärkten Rand.

*Uniform wall thickness distribution makes these flasks ideal for heating applications. Flat base means flasks can be set down without a supporting ring. Flasks with a neck diameter of 65 mm have a reinforced rim.*

Best.-Nr. Cat. No.	Inhalt Capacity ml	d mm	d <sub>1</sub> mm	h mm	Verpackungseinheit/ Stück Pack/Quantity
21 711 17	50	51	26	90	10
21 711 24	100	64	26	105	10
21 711 36	250	85	34	138	10
21 711 44	500	105	34	163	10
21 711 54	1 000	131	42	190	10
21 711 64 <sup>1</sup>	2 000	166	42	250	10
21 711 68 <sup>1</sup>	3 000	185	50	250	1
21 711 71	4 000	207	50	275	1
21 711 73 <sup>1</sup>	5 000	223	50	290	1
21 711 76	6 000	237	65	315	1
21 711 86	10 000	280	65	360	1

<sup>1</sup> Nicht nach DIN ISO.

<sup>1</sup> Non-DIN ISO size.

**DURAN® STEHKOLBEN**  
**weithalsig, mit Bördelrand**

**DURAN® FLAT BOTTOM FLASK**  
**wide neck, with beaded rim**

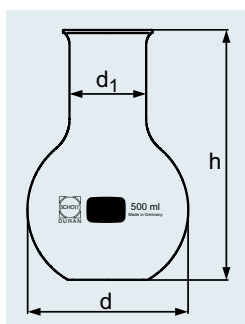

Stehkolben eignen sich durch die gleichmäßige Wandstärke ideal als Kochglas. Durch den flachen Boden kann der Kolben abgestellt werden. Bequemes Befüllen und Entnehmen durch den weiten Hals. Kolben mit einem Halsdurchmesser von 76 mm haben einen verstärkten Rand.

*Uniform wall thickness distribution makes these flasks ideal for heating applications. Flat base means flasks can be set down without a supporting ring. The wide neck permits easy filling and removal of flask contents. Flasks with a neck diameter of 76 mm have a reinforced rim.*

Best.-Nr. Cat. No.	Inhalt Capacity ml	d mm	d <sub>1</sub> mm	h mm	Verpackungseinheit/ Stück Pack/Quantity
21 731 17	50	51	34	90	10
21 731 24	100	64	34	105	10
21 731 36	250	85	50	138	10
21 731 44	500	105	50	163	10
21 731 54	1 000	131	50	190	10
21 731 63 <sup>1</sup>	2 000	166	76	230	10
21 731 64	2 000	166	50	230	10

<sup>1</sup> Nicht nach DIN EN ISO.

<sup>1</sup> Non-DIN EN ISO size.

Englerkolben eignen sich durch die gleichmäßige Wandstärke ideal als Kochglas und für Destillationen.

*Uniform wall thickness distribution makes these flasks ideal for heating applications and distillations.*

Best.-Nr. Cat. No.	Inhalt Capacity ml	d mm	d <sub>i</sub> mm	h mm	Seitenrohr Side arm		Verpackungseinheit/ Stück Pack/Quantity
					d <sub>s</sub> mm	l mm	
21 653 24	100	66	20	215	6	100	10
21 653 28	125	68	22	215	7	100	10
21 653 29	150	73	20	223	6	100	10

**DURAN® ENGLERKOLBEN**  
**mit seitlichem Auslass**

**DURAN® ENGLER FLASK**  
**with side outlet**

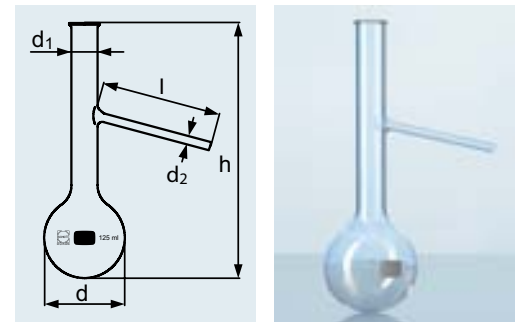

Englerkolben eignen sich durch die gleichmäßige Wandstärke ideal als Kochglas und für Destillationen.

*Uniform wall thickness distribution makes these flasks ideal for heating applications and distillations.*

Best.-Nr. Cat. No.	Inhalt Capacity ml	d mm	h mm	Seitenrohr Side arm		Verpackungseinheit/ Stück Pack/Quantity
				d <sub>s</sub> mm	l mm	
24 653 28	125	68	215	7	100	10

**DURAN® ENGLERKOLBEN**  
**mit NS 19/26 Hülse, seitlicher Auslass**

**DURAN® ENGLER FLASK**  
**with standard ground joint 19/26, side outlet**

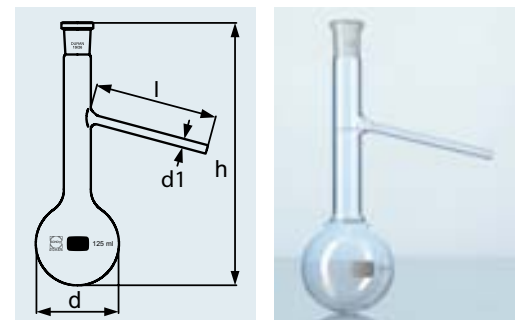

**GLASKERAMIK LABOR-  
SCHUTZPLATTE**

**GLASS CERAMIC LABORATORY  
PROTECTION PLATE**

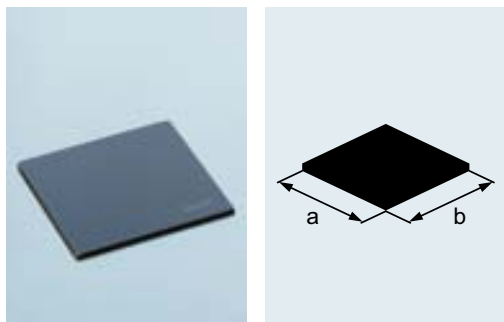

Durch die geringe Ausdehnung und die dadurch geringen Spannungen eignen sich die Glaskeramikplatten sehr gut zum Erhitzen von Kochgläsern mit dem Bunsenbrenner.

*Due to low thermal expansion stresses, these glass ceramic plates are well suited to heating glassware with a Bunsen burner.*

Best.-Nr. Cat. No.	Abmessungen der Platte Plate dimensions a x b mm	Verpackungseinheit/ Stück Pack/Quantity
23 821 53	135 x 135	10
23 821 57	155 x 155	10
23 821 58	175 x 175	10

**VIERKANTFUSS  
für Glaskeramik Laborschutzplatte**

**SQUARE QUADRUPOD  
for glass ceramic laboratory protection plate**



Plattenhalter für Glaskeramikplatten. Aus temperaturbeständigem Chrom-Nickelstahl, sehr gutes Standverhalten durch vier Füße und stabile Bauart.

*Plate holder for glass ceramic plates. Made from heat-resistant chrome-nickel steel with four legs for extra stability.*

Best.-Nr. Cat. No.	Für Platte For plates mm	Abmessungen der Platte Plate dimensions a x b mm	h mm	Verpackungseinheit/ Stück Pack/Quantity
29 077 53	23 821 53	135 x 135	210	5
29 077 57	23 821 57	155 x 155	210	5
29 077 58	23 821 58	175 x 175	220	5

**PLATTENHALTER  
für Glaskeramik Laborschutzplatte**

**PLATE HOLDER  
for glass ceramic laboratory protection plate**

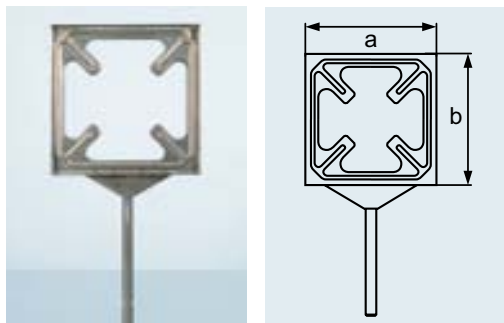

Stativ-Plattenhalter für Glaskeramikplatten. Aus temperaturbeständigem Chrom-Nickelstahl.

*Plate holder for glass ceramic plates. Made from heat-resistant chrome-nickel steel.*

Best.-Nr. Cat. No.	Für Platte For plates mm	Abmessungen der Platte Plate dimensions a x b mm	Verpackungseinheit/ Stück Pack/Quantity
29 078 53	23 821 53	135 x 135	5
29 078 57	23 821 57	155 x 155	5
29 078 58	23 821 58	175 x 175	5

Ideal zur Reinigung von Glaskeramikplatten. *Ideal for cleaning glass ceramic plates.*

Best.-Nr. Cat. No.	Verpackungseinheit/Stück Pack/Quantity
29 079 01	10

REINIGUNGSSCHABER  
für Glaskeramik Laborschutzplatte

CLEANING SCRAPER  
for glass ceramic laboratory protection plate

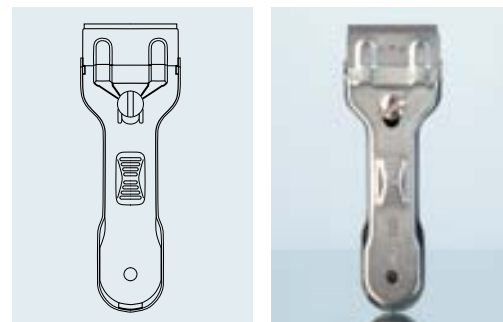

Best.-Nr. Cat. No.	Inhalt Capacity ml	d mm	h mm	Verpackungseinheit/ Stück Pack/Quantity
Ohne Tülle und Docht <i>Without socket and wick</i>				
23 400 24	100	75	103	10
Komplett mit Tülle und Docht <i>Complete with socket and wick</i>				
23 400 24 5	100	75	103	10
Zubehör für Spiritusbrenner: <i>Accessories for spirit lamp:</i>				
Dochte für Spiritusbrenner <i>Wicks for spirit lamps</i>				
29 402 00				50
Tüllen für Spiritusbrenner (aus Aluminium) <i>Sockets for spirit lamps (of aluminium)</i>				
29 403 00				50

SPIRITUSBRENNER  
AUS KALK-SODA-GLAS  
ohne Einfüllstutzen, mit aufgeschliffener Kappe

SPIRIT LAMP  
FROM SODA-LIME GLASS  
without filling tubulature, with ground over-cap

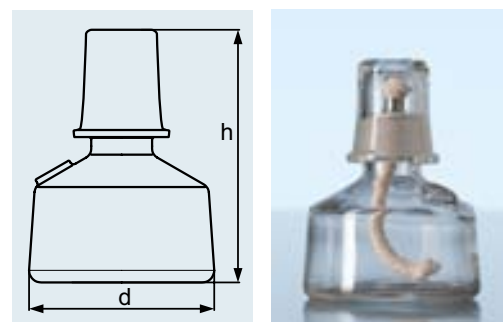

Best.-Nr. Cat. No.	Inhalt Capacity ml	d mm	h mm	Verpackungseinheit/ Stück Pack/Quantity
21 301 32 <sup>1</sup>	15	50	25	10
21 301 34 <sup>1</sup>	45	60	30	10
21 301 38 <sup>2</sup>	60	70	35	10
21 301 41 <sup>2</sup>	90	80	45	10
21 301 44	170	95	55	10
21 301 49	320	115	65	10
21 301 54	600	140	80	10
21 301 59	1 500	190	100	10
21 301 63	2 500	230	130	10

<sup>1</sup> Ohne Aufdruck.  
<sup>2</sup> Ohne Schriftfeld.

<sup>1</sup> Without print.  
<sup>2</sup> Without labelling field.

DURAN® ABDAMPFSCHALE  
mit Ausguss

DURAN® EVAPORATING DISHES  
with spout

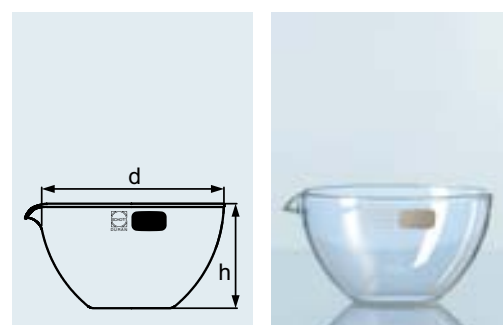

DIN 12336 A 121 °C

**KOCHGLÄSER UND ALLGEMEINES LABORGLAS**  
**BOILING FLASKS AND GENERAL LABORATORY GLASSWARE**

**DURAN® KRISTALLISIERSCHALE**  
**mit und ohne Ausguss**

**DURAN® CRYSTALLIZING DISH**  
*with and without spout*

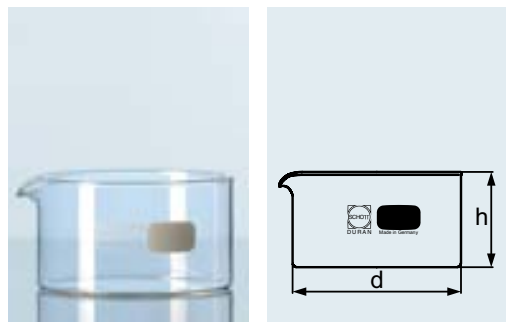

Best.-Nr. Cat. No.	Inhalt Capacity ml	d mm	h mm	Verpackungseinheit/ Stück Pack/Quantity
Mit Ausguss DIN 12 338 With spout DIN 12 338				
21 311 24 <sup>1</sup>	20	40	25	10
21 311 32 <sup>1</sup>	40	50	30	10
21 311 34 <sup>1</sup>	60	60	35	10
21 311 38	100	70	40	10
21 311 41	150	80	45	10
21 311 44	300	95	55	10
21 311 49	500	115	65	10
21 311 54	900	140	75	10
21 311 59	2 000	190	90	10
21 311 63	3 500	230	100	10
Ohne Ausguss DIN 12 337 Without spout DIN 12 337				
21 313 24 <sup>1</sup>	20	40	25	10
21 313 32 <sup>1</sup>	40	50	30	10
21 313 34 <sup>1</sup>	60	60	35	10
21 313 38	100	70	40	10
21 313 41	150	80	45	10
21 313 44	300	95	55	10
21 313 49	500	115	65	10
21 313 54	900	140	75	10
21 313 59	2 000	190	90	10
21 313 63	3 500	230	100	10

<sup>1</sup> Ohne Aufdruck.

<sup>1</sup> Without print.

**DURAN® WÄGEGLAS**  
**mit eingeschliffenem Deckel**

**DURAN® WEIGHING BOTTLE**  
*with ground lid*

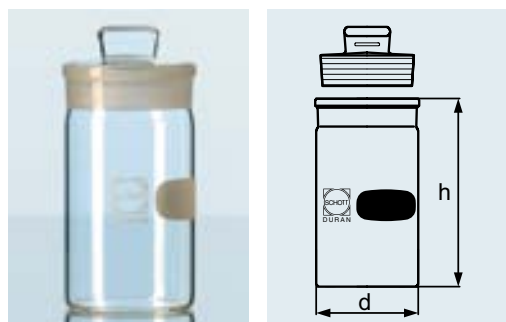

Durch den dichten Verschluss kann ein Probenverlust beim Transport nach dem Abwiegen verhindert werden. In niedriger und hoher Form erhältlich.

*Close-fitting lid prevents any sample loss during transport after weighing. Available in low and high forms.*

Best.-Nr. Cat. No.	Inhalt Capacity ml	d x h mm	Verpackungseinheit/ Stück Pack/Quantity
Niedrige Form Flat shape			
24 210 13	5	28 x 25	10
24 210 23	15	38 x 30	10
24 210 32	30	54 x 30	10
24 210 41	80	85 x 30	10
Hohe Form Tall shape			
24 211 13	10	28 x 40	10
24 211 18	20	32 x 50	10
24 211 23	45	38 x 70	10
24 211 24	70	44 x 80	10



In DURAN® und Kalk-Soda-Glas erhältlich  
(Eigenschaften siehe Seiten 187–191, 204.)

Available in DURAN® and also in *soda-lime glass* (for properties, see pages 217–222, 234).

DURAN® UHRGLASSCHALE  
Rand verschmolzen

DURAN® WATCH GLASS DISH  
fused rim

Best.-Nr. Cat. No.	d mm	Verpackungseinheit/Stück Pack/Quantity
DURAN®		
21 321 24	40	10
21 321 32	50	10
21 321 34	60	10
21 321 41	80	10
21 321 46	100	10
21 321 52	125	10
21 321 57	150	10
21 321 61	200	10
21 321 66	250	1
Kalk-Soda-Glas Soda-lime glass		
23 321 24	40	10
23 321 32	50	10
23 321 34	60	10
23 321 38	70	10
23 321 41	80	10
23 321 43	90	10
23 321 46	100	10
23 321 51	120	10
23 321 52	125	10
23 321 57	150	10
23 321 61	200	10
23 321 66	250	10

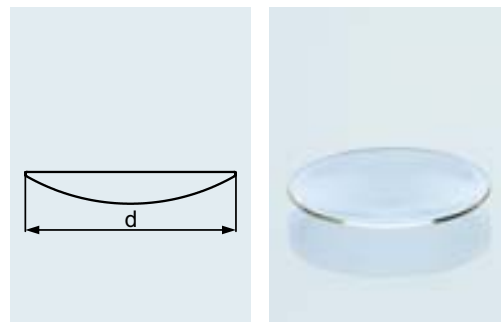

Best.-Nr. Cat. No.	Inhalt Capacity ml	d mm	h mm	Verpackungseinheit/ Stück Pack/Quantity
24 204 23	75	50	70	10
24 204 24	100	54	75	10

DURAN® ORGANGLAS  
ohne Stopfen

DURAN® ORGAN STORAGE JAR  
without stopper

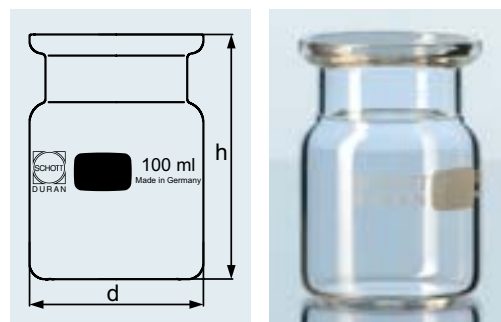

**KOCHGLÄSER UND ALLGEMEINES LABORGLAS**  
**BOILING FLASKS AND GENERAL LABORATORY GLASSWARE**

**DURAN® DOSE**  
 mit Deckel

*DURAN® JAR*  
 with lid

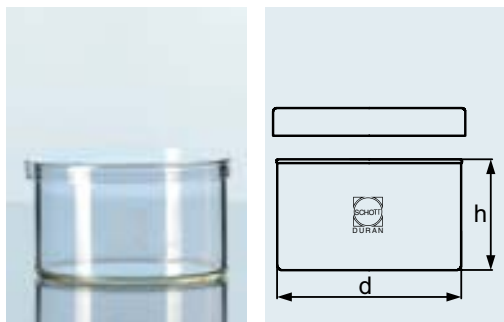

Best.-Nr. Cat. No.	d x h mm	Volumen ca. Volume approx. ml	Verpackungseinheit/ Stück Pack/Quantity
24 208 34	60 x 40	75	10
24 208 41	80 x 50	175	10
24 208 45	100 x 60	325	10
24 208 57	150 x 80	1 000	10

**DURAN® DOSE**  
 mit Falz und Deckel

*DURAN® JAR*  
 with shoulder and lid



Best.-Nr. Cat. No.	d x h mm	Volumen ca. Volume approx. ml	Verpackungseinheit/ Stück Pack/Quantity
24 207 34	60 x 35	70	10
24 207 45	103 x 55	250	10
24 207 51	121 x 64	500	10

DIN  
12340

**DURAN® ZYLINDER**  
 mit Knopfdeckel, Rand poliert

*DURAN® CYLINDER*  
 with knobbed lid, polished rim

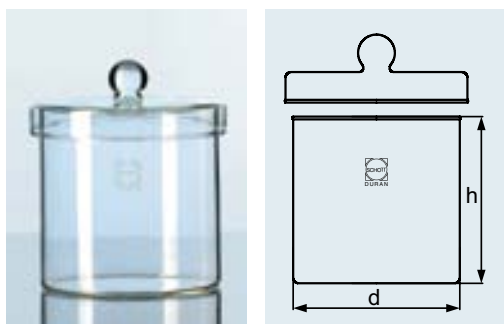

Best.-Nr. Cat. No.	d x h mm	Volumen ca. Volume approx. ml	Verpackungseinheit/ Stück Pack/Quantity
24 205 01	80 x 80	250	10
24 205 03	100 x 100	500	10
24 205 05	120 x 120	1 000	1
24 205 10	150 x 150	2 000	1
24 205 21	210 x 210	6 000	1
24 205 32	260 x 260	12 000	1

Best.-Nr. Cat. No.	Inhalt Capacity ml	d mm	Schliffgröße Grinding height mm	h mm	h <sub>1</sub> mm	Verpackungseinheit/ Stück Pack/Quantity
21 580 24	100	52	34,5	135	39	10
21 580 39	300	69	45	163	48	10
21 580 48	600	81	50	214	50	10
21 580 51	750	90	60	240	57	10
21 580 58	1 200	100	60	253	57	10

**DURAN® AUSSTELLUNGS-  
SCHAUGLAS**

**DURAN® SPECIMEN JAR**

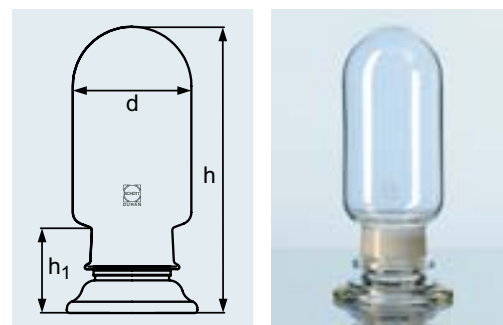

Durch den präzisen Schliff an Deckel und Gefäßunterteil wird ein dichtes Verschließen ermöglicht.

*The precise grinding of the knobbed lid and base vessel enables a very tight seal.*

**DURAN® PRÄPARATENGLAS  
mit eingeschliffenem Knopfdeckel**

**DURAN® SPECIMEN JAR  
with ground, knobbed lid**

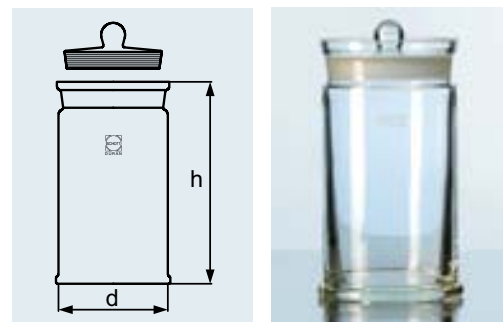

Best.-Nr. Cat. No.	d x h mm	Volumen ca. Volume approx. ml	Verpackungseinheit/ Stück Pack/Quantity
24 209 02	65 x 63	125	10
24 209 09	65 x 103	250	10
24 209 11	110 x 103	800	10
24 209 16	85 x 123	600	10
24 209 17	127 x 123	1 400	1
24 209 24	85 x 153	750	1
24 209 26	110 x 153	1 250	1
24 209 28	157 x 153	2 500	1
24 209 38	110 x 203	1 750	1
24 209 39	157 x 203	4 000	1
24 209 49	110 x 253	2 000	1
24 209 50	157 x 253	4 500	1
24 209 57	120 x 300	2 250	1
24 209 59	252 x 303	13 000	1

Durch den präzisen Schliff an Glasplatte und Gefäßunterteil wird ein dichtes Verschließen ermöglicht.

*The precise grinding of the glass plate and base vessel enables a very tight seal.*

**DURAN® PRÄPARATENKASTEN  
mit aufgeschliffener Glasplatte**

**DURAN® MUSEUM JAR  
with ground glass plate**

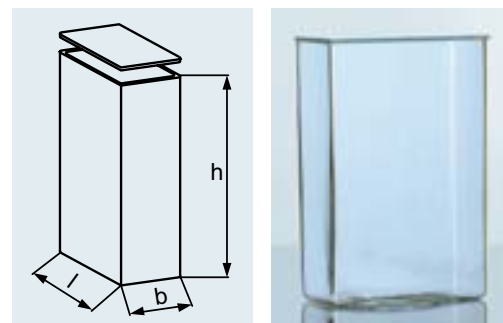

Best.-Nr. Cat. No.	l x b x h mm	Verpackungseinheit/ Stück Pack/Quantity
21 363 05	60 x 50 x 100	10
21 363 11	100 x 50 x 120	1
21 363 13	130 x 50 x 130	1
21 363 19	150 x 50 x 150	1
21 363 28	120 x 60 x 180	1
21 363 47	210 x 100 x 210	1
21 363 58	250 x 140 x 250	1

**DURAN® MEHRZWECKZYLINDER**  
**mit rundem Fuß**

**DURAN® MULTI-PURPOSE CYLINDER**  
**with round base**

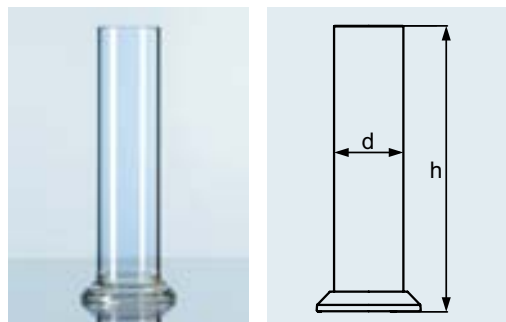

Der Rand ist rau abgeschliffen.

*Rough ground rim.*

Best.-Nr. Cat. No.	d x h mm	Volumen ca. Volume approx. ml	Verpackungseinheit/ Stück Pack/Quantity
21 398 21	50 x 150	300	10
21 398 34	40 x 200	250	10
21 398 36	60 x 200	570	10
21 398 46	60 x 250	700	10
21 398 52	40 x 300	380	10
21 398 53	50 x 300	600	10
21 398 68	40 x 400	500	10
21 398 74	80 x 400	2 000	10
21 398 77	65 x 450	1 500	10
21 398 80	50 x 500	1 000	10

**DURAN® STANDZYLINDER**  
**mit rundem Fuß**

**DURAN® STANDING CYLINDER**  
**with round base**

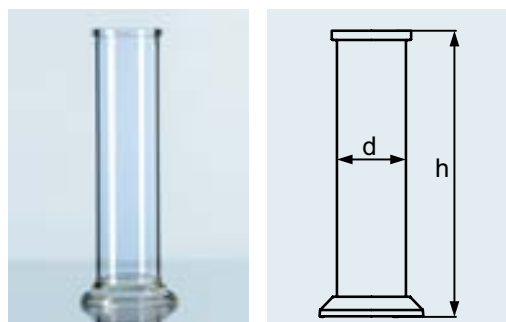

Der Rand ist umgelegt und plangeschliffen.

*Plane ground rim.*

Best.-Nr. Cat. No.	d x h mm	Volumen ca. Volume approx. ml	Verpackungseinheit/ Stück Pack/Quantity
21 399 07	40 x 100	130	10
21 399 34	40 x 200	250	10
21 399 36	60 x 200	570	10
21 399 46	60 x 250	700	10
21 399 68	40 x 400	500	10

**DURAN® PLANFLANSCHGLOCKE**  
**mit Knopf**

**DURAN® BELL JAR**  
**with knob**

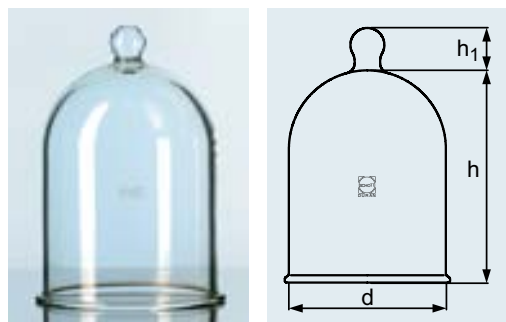

Aufgrund der Wandstärke und Geometrie  
 vakuumfest.

*Wall thickness and geometry designed  
 to suit vacuum applications.*

Best.-Nr. Cat. No.	h + h <sub>1</sub> mm	h x d mm	Verpackungseinheit/ Stück Pack/Quantity
24 460 59	300	250 x 185	1
24 460 66	305	255 x 260	1
24 460 69	350	300 x 315	1

Aufgrund der Wandstärke und Geometrie vakuumfest. Öffnung im Hals mit Normschliff 34/35.

Wall thickness and geometry designed to suit vacuum applications. Neck aperture, standard ground joint 34/35.

**DURAN® PLANFLANSCHGLOCKE mit Öffnung im Hals**

**DURAN® BELL JAR with aperture in neck**

Best.-Nr. Cat. No.	h + h <sub>1</sub> mm	h x d mm	NS	Verpackungseinheit/ Stück Pack/Quantity
24 465 59	300	250 x 185	34/35	1
24 465 61	350	300 x 215	34/35	1
24 465 69	550	500 x 315	34/35	1

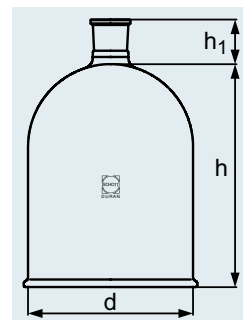

Skaleneinteilung und Fehlergrenzen siehe Tabelle:

For scale divisions and accuracy limits, see table:

**DURAN® SEDIMENTIERGEFÄß nach Imhoff, graduert**

**DURAN® SEDIMENTATION CONE Imhoff type, graduated**

Best.-Nr. Cat. No.	Inhalt Capacity ml	Größter d Max. d mm	h mm	Verpackungseinheit/ Stück Pack/Quantity
21 401 54	1 000	120	470 max.	10

Graduierung Scale ml	Teilung Division ml	Toleranz +/- Tolerance +/- ml
0-2	0,1	0,1
2-10	0,5	0,5
10-40	1	1
40-100	2	2
1 000	Ringmarke / Circular marking	10

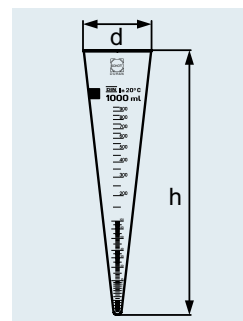

DIN  
12672

## KOCHGLÄSER UND ALLGEMEINES LABORGLAS BOILING FLASKS AND GENERAL LABORATORY GLASSWARE

### DURAN® REAGENZGLAS mit Bördelrand oder geradem Rand

#### DURAN® TEST TUBE with beaded rim or straight rim

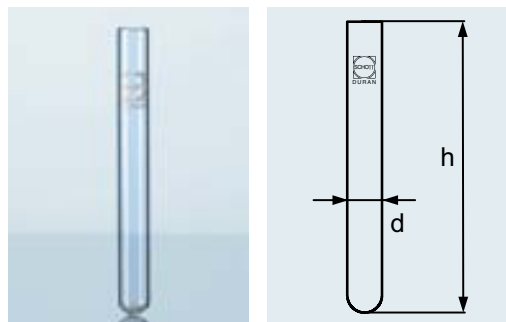

Sortimentserweiterung!  
Extended range!

Die Reagenzgläser sind dickwandig und deshalb mechanisch besonders widerstandsfähig. Sie bieten dennoch eine gute Temperaturwechselbeständigkeit.

The test tubes are thick-walled and therefore mechanically very resistant, yet still retain good thermal shock resistance.

Best.-Nr. Bördelrand Cat. No. Beaded rim	Best.-Nr. Rand gerade Cat. No. Straight rim	d x h mm	ca. Volumen approx. vol. ml	Wanddicke Wall thickness mm	Verpackungseinheit/ Stück Pack/Quantity
26 130 01	26 131 01	8 x 70	2	0,8-1,0	100
26 130 03	26 131 03	10 x 75	4	0,8-1,0	100
26 130 06	26 131 06	10 x 100	5	0,8-1,0	100
26 130 08	26 131 08	12 x 75	6	0,8-1,0	100
26 130 11	26 131 11	12 x 100	8	0,8-1,0	100
26 130 12	26 131 12	13 x 100	9	0,8-1,0	100
26 130 13	26 131 13	14 x 130	16	0,8-1,0	100
26 130 16	26 131 16	16 x 130	17	1,0-1,2	100
26 130 21	26 131 21	16 x 160	21	1,0-1,2	100
26 130 23	26 131 23	18 x 180	32	1,0-1,2	100
26 130 26	26 131 26	20 x 150	34	1,0-1,2	100
26 130 28	26 131 28	20 x 180	40	1,0-1,2	100
26 130 33	26 131 33	25 x 150	55	1,0-1,2	50
26 130 36	26 131 36	25 x 200	70	1,0-1,2	50
26 130 38	26 131 38	30 x 200	100	1,0-1,4	50

### FIOLAX® BOROSILIKATGLAS REAGENZGLAS mit Bördelrand

#### FIOLAX® BOROSILICATE TEST TUBE with beaded rim

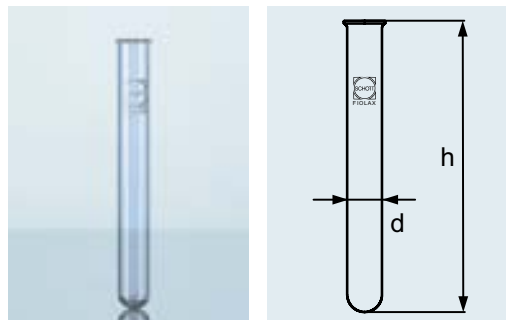

Die Reagenzgläser sind dünnwandig und somit unempfindlich gegen rasche Temperaturwechsel und lokale Erhitzung.

Thin-walled test tubes suited to rapid temperature changes or localized heating.

Best.-Nr. Cat. No.	d x h mm	ca. Volumen approx. vol. ml	Wanddicke Wall thickness mm	Verpackungseinheit/ Stück Pack/Quantity
26 110 01	8 x 70	2	0,4-0,5	100
26 110 03	10 x 75	4	0,4-0,5	100
26 110 06	10 x 100	6	0,4-0,5	100
26 110 08	12 x 75	6,5	0,4-0,5	100
26 110 11	12 x 100	9	0,4-0,5	100
26 110 13	14 x 130	16	0,4-0,5	100
26 110 16	16 x 130	20	0,5-0,6	100
26 110 21	16 x 160	25	0,5-0,6	100
26 110 23	18 x 180	35	0,5-0,6	100
26 110 26	20 x 150	39	0,5-0,6	100
26 110 28	20 x 180	45	0,5-0,6	100
26 110 33	25 x 150	60	0,6-0,7	50
26 110 36	25 x 200	80	0,6-0,7	50
26 110 38	30 x 200	110	0,7-0,8	50

Die NMR Röhren sind entsprechend den Anforderungen in drei Genauigkeits-klassen erhältlich. Je nach Magnetfeld und Spin kann das passende Röhren ausgewählt werden. Die Röhren zeichnen sich durch engste Toleranzen und höchste Präzision aus. Dies betrifft besonders die Geradheit, Wandstärke und Wandstärkenverteilung. Dadurch werden schnelle und genaue Versuchsergebnisse ermöglicht.

*NMR tubes are available, according to requirement, in three accuracy classes. The correct tube can be selected depending on magnetic field and spin. These tubes are noteworthy for their close tolerances and accuracy, especially to their straightness, wall thickness and wall thickness distribution. Consequently, quick and accurate test results are achievable.*

## NMR TUBES drei Genauigkeitsklassen

### NMR TUBES three accuracy classes

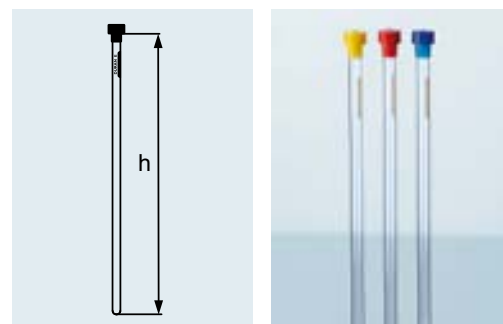

Best.-Nr. Cat. No.	h mm	AD OD mm	ID iD mm	Gradheit Camber mm	MHZ	Verpackungseinheit/ Stück Pack/Quantity
Economic mit Retrace Code   with Retrace Code						
23 170 01 17 <sup>1</sup>	178	4,95+/- 0,05	4,20 +/- 0,05	0,07	300	250
Professional						
23 170 02 11	178	4,97+/- 0,025	4,20 +/- 0,025	0,03	400	250
Scientific						
23 170 03 14	178	4,97+/- 0,013	4,20 +/- 0,025	0,013	500	5

<sup>1</sup> DURAN®.

<sup>1</sup> DURAN®.

Best.-Nr. Cat. No.	Farbe Colour	Verpackungseinheit/Stück Pack/Quantity
29 917 01	blau   blue	250
29 917 02	rot   red	250
29 917 03	gelb   yellow	250
29 917 04	schwarz   black	250
29 917 05	grün   green	250

## ERSATZ-VERSCHLÜSSE FÜR NMR TUBES aus EVA<sup>1</sup>

### SPARE CAPS FOR NMR TUBES from EVA<sup>1</sup>

<sup>1</sup> Chemische und thermische Beständigkeit siehe Seite 192.

<sup>1</sup> For chemical and thermal resistance, see page 222.